

## Gema Lingkungan Kesehatan

Vol. 24, No. 2 (2026), pp 242-252

e-ISSN 2407-8948 p-ISSN 16933761

doi: <https://doi.org/10.36568/gelinkes.v24i2.379> Journal Homepage: <https://gelinkes.poltekkesdepkes-sby.ac.id/>

### Determination of Waste Processing Options to Extend Landfill Service Life

Murwan Widyantoro<sup>1,2\*</sup>, Suprihatin Suprihatin<sup>2</sup>, Nastiti Siswi Indrasti<sup>2</sup>, Tajuddin Bantacut<sup>2</sup>

<sup>1</sup> Department of Industrial Engineering, Faculty of Technology, Bhayangkara Jakarta Raya University, Bekasi, Indonesia

<sup>2</sup> Study Program of Agroindustrial Engineering, Bogor Agricultural University, Indonesia

\*Correspondence: [murwanwidyantoro@apps.ipb.ac.id](mailto:murwanwidyantoro@apps.ipb.ac.id)

Waste reduction and handling in landfills is still a problem. Waste that accumulates in landfills can threaten the life and capacity of the landfill. Therefore, waste processing in landfills must be resolved properly to reduce the negative impacts it causes. This study aims to choose the best scenario option for processing organic waste, especially food waste, so that it can prolong the landfill's lifespan. The research location is at Galuga Landfill because it has a food waste composition of Bogor City's total garbage production weight. The method used is Material Flow Analysis (MFA). The study's results indicated that Scenario 1 resulted in 40% of organic waste being sent to landfills, which extended the landfill's lifespan by 8 years. In contrast, Scenario 2 produced 35% of organic waste destined for landfills, adding 10 years to the landfill's lifespan. The last scenario 3 was 8% with the landfill age being 16 years longer. In conclusion, this study finds that scenario 3 is the most promising option. It not only generates products with high economic value but also helps to extend the lifespan of the landfill compared to other scenarios.

**Keywords:** Biogas, Compost, CORS, Landfill

#### INTRODUCTION

The current growth in waste production is a very important challenge for sustainable development in some large cities (Burin et al., 2025) Currently, most of this waste is only collected and disposed of in landfills. (Jindal & Sar, 2023) , leading to the creation of open dumping sites, which raises significant concerns about landfill conditions. Food waste has on average ranked first in the composition of municipal waste that fills landfills, followed by paper/cardboard, wood/twigs, plastic, metal, cloth, rubber/leather, glass, and others (Joseph, 2014). Food waste refers to food that is lost or discarded and is meant for human consumption (Adelodun et al., 2021) Food waste is a significant global issue, particularly in developing countries, and it contributes greatly to environmental problems worldwide (Fuss et al., 2020); (Dhir et al., 2020) (Jäger-Roschko & Petersen, 2022), (Wang & Su, 2020) (Karakadzai et al., 2021) (SHABANI & JERIE, 2022) (Maleknia, 2025) (Yasmeen & Longsheng, 2025) One-third of human food production and consumption turns into waste, including biodegradable organic waste such as fruit and vegetable peels and pulp (Gustafsson et al., 2013) ; (Simeone & Scarpato, 2020) In addition, the drive for consumer behavior to buy excessive food without awareness of the waste it produces also contributes significantly to waste (Aschemann-Witzel

et al., 2019) It is noted that solid waste has now increased fourfold higher than in the previous forty years (Aschemann-Witzel et al., 2019; Di Foggia & Beccarello, 2021; Zhang & Sun, 2023), and It is projected to rise to 2.3 billion tons by 2025.

Solid food waste has a high organic content (between 40-60%) (S. Varjani et al., 2022) . Neglecting proper management and disposal of organic waste results in harmful consequences, including foul odors and greenhouse gas emissions that contribute to global warming, decreased water quality, health problems, the emergence of insects, and ultimately harms both humans and the environment (O'Connor et al., 2023); (Kala et al., 2022); (Arun & Sivashanmugam, 2015) ; (Koda et al., 2022); (Shen et al., 2025)). Disposal of organic waste in landfills can produce sources of anthropogenic atmospheric methane gas (Spokas et al., 2003); (Bian et al., 2018); (Ouzeau et al., 2016), Methane gas, a powerful greenhouse gas, is released during the anaerobic decomposition of organic matter in landfills (Camilleri, 2025) , and contributes about 3% of the total annual global greenhouse gas (GHG) emissions (Fan et al., 2016)). Methane is a potent greenhouse gas (GHG) with a heat-trapping ability that is 25 times greater than that of carbon dioxide (Kashyap et al., 2023), which can transform the troposphere and have a negative impact on climate

((Agarwal et al., 2023). Based on these conditions, it is urgent to explore organic waste processing technologies that can produce useful, high-value, and sustainable products (Arun & Sivashanmugam, 2015);(Rahman & Alam, 2022). In recent decades, waste processing has received increased attention due to its numerous benefits, the zero-waste concept, improved economic performance, and compatibility with a variety of raw materials. (wet and dry) ((S. J. Varjani & Upasani, 2017; Yaashikaa et al., 2020).

Organic waste processing in landfills can be done in various ways. Conventional organic waste processing usually includes biological conversion such as anaerobic fermentation that produces biogas, aerobic fermentation, and insect conversion (Jin et al., 2023), while high-level waste processing can be done by converting waste into energy-dense products technology related to thermochemistry (e.g. incineration, pyrolysis, gasification, and hydrothermal liquefaction) and biochemical processes (such as fermentation, anaerobic digestion, composting, and landfilling) (Kundariya et al., 2021)(Aydoğmuş et al., 2022) In order to improve the added value of goods, all of these organic waste treatment methods seek to decrease their bulk and volume, eliminate biodegradable elements, and offer chances for energy recovery. They can also extend the landfill's usable life (Yiwei et al., 2024).

This study explores three scenarios for processing organic waste. Composting techniques are very popular in the community as a widely recognized as sustainable practices (Jerie et al., 2024). Scenario 2 is an anaerobic processing technology that produces biogas. The calorific value and fuel content of biogas are high, or contains around 60% methane (Habibur Rahman et al., 2023), in order for it to become a sustainable energy source and lessen negative environmental effects. Finally, Scenario 3 is CORS Technology which produces a source of protein. The digestion of organic waste with Black Soldier Fly (BSF) larvae will be the main focus of this investigation. BSF was chosen because of its easy life cycle, does not act as a carrier of human pathogens, and can quickly convert large amounts of organic and commercial waste (Tomba et al., 2022)

Innovation in selecting technology for proper waste management can provide significant opportunities both in

terms of economy and valuable resources such as biogas or organic fertilizer (Yasmeen & Longsheng, 2025). Based on this context, the goal of this study is to determine the optimal scenario choice for processing organic waste that will prolong the landfill's lifespan.

## METHOD

Located for research in Bogor City-Indonesia, specifically at Galuga Landfill. The selection of this research location was based on the fact that this location has the largest potential for organic waste produced in Bogor City. The area of Galuga Landfill consists of facilities and infrastructure, landfills, and others which reach 31.8 ha, with an active zone of 9 ha and a passive zone of 3 ha (Nurzaki, 2021).



**Figure 1.** Galuga Landfill - Bogor City, Indonesia

The waste that enters the Galuga Landfill is currently still mixed, making it difficult to manage. The waste management system currently implemented at the Galuga Landfill is still in the form of collection from waste sources, transportation, and open dumping. A waste management system like that will not be able to reduce waste significantly and massively, or in other words, the amount of waste that ends up at the Galuga Landfill is not much different from the amount of waste produced from sources (households, offices, markets, businesses, public facilities, areas, and so on) every day.



**Figure 2.** Waste Pile At Bogor City - Indonesia (Joseph, 2014)

Until now, there has been no method that can be done to overcome the issue of waste management, especially in the Galuga landfill. The variety of types and forms of waste makes it difficult to build and operate an efficient solid waste collection system. If this continues without any management changes, the lifespan of the landfill may undoubtedly be determined based on the quantity of garbage disposed, certainly the lifespan of the landfill will not be much longer. The MFA graph for the waste pile existing at the Galuga landfill in 2023 can be seen in Figure 3.

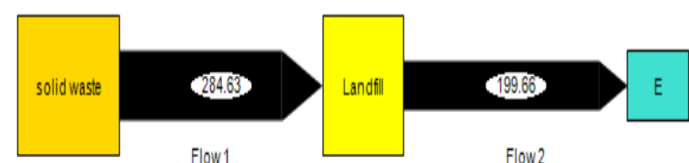

**Figure 3.** Existing Waste Diagram Of Galuga Landfill, Bogor City In 2023 (Joseph, 2014)

In 2023, Galuga landfill processed its waste using the waste bank method, composting, and small-scale renewable energy treatment, so that the final result of the processing is 199.655 tons and is disposed of directly into the landfill. The quantity of rubbish deposited in a landfill may be used to determine its age. Referring to data from the research of (Lesmana & Tawaqal, 2021) with regional conditions and community life patterns that tend to be similar, stating that the waste density is 0.0003 Ton/m<sup>3</sup>. The area needed for waste generation in the landfill is 113.88 m<sup>2</sup>/year. Through a simple extrapolation calculation for the waste generation of Bogor City, the equation  $y = 2870x^2 - 5753.9x + 243374$  is obtained, with

$R^2=0.9498$  so that the Galuga landfill can be calculated around  $\pm 28$  years.

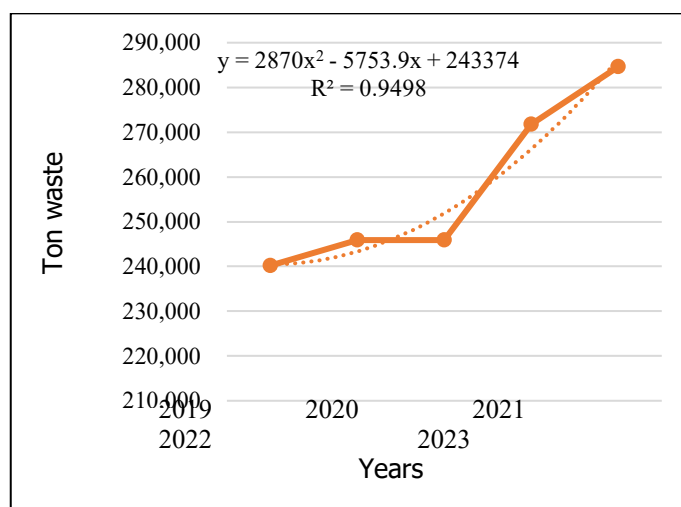

**Figure 4.** The Equation For Waste Generation In Bogor City (Joseph, 2014)

Given these circumstances, it is essential to use the waste management process to decrease the quantity of rubbish that enters the landfill in order to prolong its lifespan. An alternative solution for the Galuga landfill can be done by processing organic waste into a product that has higher added value by considering its supporting aspects. This study uses the MFA method in organic waste management activities, especially food waste. This is done because food waste ranks first in the composition of waste in the city of Bogor, or 40% more than other types of waste. the trash composition in the city of Bogor according to the kind of garbage, can be seen in Figure 5.

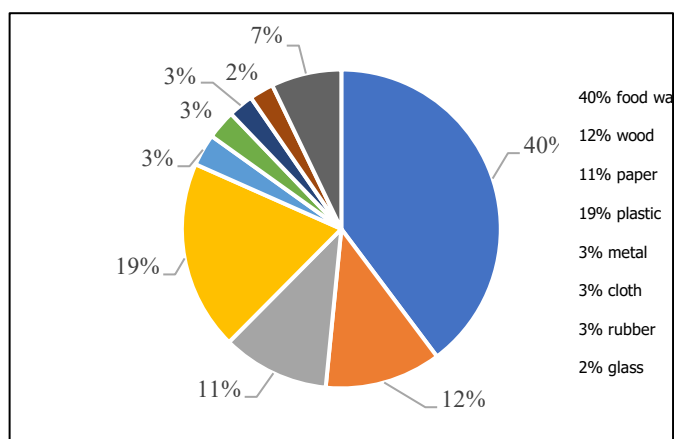

**Figure 5.** Waste Composition Based On Waste Type At Galuga Landfill, Bogor City-Indonesia (Joseph, 2014)

In this study, the method of selecting 3 management scenario options was used, namely (1) scenario 1 is organic waste processing using Aerobic Composting technology, producing compost, (2) scenario 2 is organic waste processing using Anaerobic Decomposition technology, producing biogas, and (3) scenario 3 is organic waste processing using Conversion of Organic Refuse by Saprophages (CORS) Technology, producing protein sources. The 3 scenarios will be presented using a waste flow diagram using Material flow analysis (MFA). MFA is the ideal instrument for research system-based material flows and stocks. MFA provides insight into system behavior and when combined with other sciences such as energy flow analysis, economic analysis, and consumer-oriented analysis, MFA also facilitates control of anthropogenic systems (Cudjoe & Acquah, 2021). The tool used for this study is software called substance flow analysis (STAN) (Annisa, 2019). The waste flow produced in a management model scenario is ascertained using the material flow analysis approach, which begins with waste entering the landfill and ends with the output generated through the processing process. The model was developed based on waste data obtained from the Galuga Landfill, thus depicting the flow of waste products. The output of processed waste is calculated by multiplying the amount of waste entering by the percentage of waste. The remaining life of the landfill is calculated by calculating the amount of waste deposited after processing. This calculation determines the extent to which the landfill can be used.

$$\text{Remaining life of the landfill} = \frac{\text{landfill capacity}}{\text{waste with land cover}}$$

## RESULT AND DISCUSSION

Bogor City also has many settlements, industries, facilities, and infrastructure such as health, education, and tourism places. All of these places have the potential to be sources of waste in Bogor City which will eventually enter the Galuga landfill. The IPCC statement states that municipal waste generally has characteristics and composition that vary depending affect the local economy, waste management systems, industrial growth, and way

of life. In general, the largest component of waste is organic matter (Bhattarai et al., 2021). Inadequate waste management can produce significant greenhouse gas emissions that can result in a very large environmental burden (Sun, 2024). However, on the other hand, if organic waste management is carried out properly, it will have an important impact that it can help comprehensively improve the environment including land, water, and air (Amicarelli et al., 2021; Le Pera et al., 2022; Leon, 2024; V. L. Leonard et al., 2024). Currently, individual waste collection in Bogor City is conducted utilizing a three-wheeled motorcycle cart, after which the debris is taken straight to a temporary dump before being driven by a garbage truck to the ultimate landfill. Based on this waste collection method, it is clear that organic waste collected in Bogor City, especially food waste, is also still mixed with other waste and transported directly into the landfill without any prior processing. This situation is increasingly urgent when food waste has currently increased by 100% since 2021 (Joseph, 2014). Based on this situation, organic waste, especially food waste, really needs to be processed first before entering the landfill so that later the landfill load will be reduced and can extend the life of the landfill.

In this study, 3 options for processing food waste are offered, the first is the composting process. Waste processing, especially organic materials into compost, has not been widely carried out, as is the case in various cities in developing countries or low-income countries (Thushari & Senevirathna, 2020). Organic waste management technology through composting techniques can be used to reduce food waste (Fuss et al., 2020). Composting produces organic materials and food waste that are rich in nutrients, which may be used to increase soil fertility in agricultural applications in addition to decreasing the quantity of garbage that ends up in landfills (Galiwango & A.Gabbar, 2022); (Amicarelli et al., 2021)). Composting is an aerobic biological process that transforms organic matter through the degradation activity of different microbes together with a number of chemical and physical processes (Siles-Castellano et al., 2020) into the simplest components or stable and pathogen-free humus structures (López-González et al., 2014); (Le Pera et al., 2022). Long composting times, sluggish cellulose breakdown rates, and poor humus formation rates are some drawbacks of conventional composting methods (Sparkes et al., 2023). In previous studies, to improve composting efficiency, The physicochemical characteristics of microorganisms and organic matter can be carried out by adding exogenous bacteria so that they can increase the degradation efficiency and humification rate of organic matter (Xie et al., 2022), and the results of In terms of compost performance, cellulose breakdown rate, nutrient retention rate, and maturation rate, composting is also superior than traditional compost (Yang et al., 2025). To keep the combination wet, sustain active microbial activity, provide the mixture structure and porosity for appropriate aeration, and absorb part of the leachate created during the decomposition process, loosening agents like sawdust, yard debris, and animal manure can also be added (Makan et al., 2020). Based on the advantages discussed from

several previous studies, all food waste from Bogor City can be processed using compost processing as scenario 1 can be seen in Figure 6.

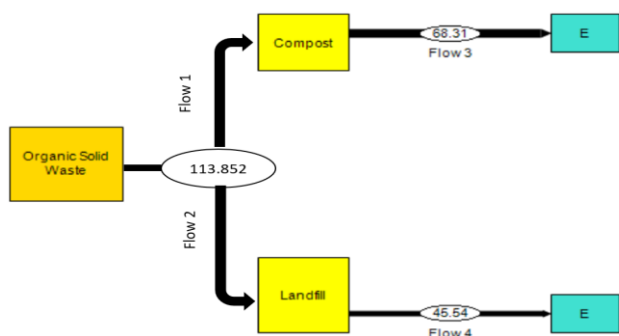

**Figure 6.** Flowchart Of Compost Processing (Scenario 1)

This section presents the research findings systematically, in the form of text, tables, and figures. Discuss the results with reference to relevant theory or previous research. The authors should provide an interpretation of the findings and explain the implications of the results for environmental health. On the other hand, in reality, compost management has not been implemented optimally, where Bogor City only has processing at the RT/RW level of approximately 17 TPS3R (Griya Wana Karya/Bubulak I; Griya Melati/Bubulak II; Rusunawa/Menteng; Rusunawa/Tanah Baru; Bumi Indrafrastra/Bantarjati; Taruna Kompos/Mulyaharja; Citra Mandiri/Kertamaya; Benteng Hijau/Lawanggingtung; Ceremai/Cipaku; Bhakti Wargana/Genteng; Tunas/Rancamaya; Mutiara/Kayumanis 1; Seremped/Cibadak I; Dharmais/Kencana I; Kencana Permai/Kencana II; Munjul/Kayumanis III; Griya Katulampa/Katulampa) which can process approximately 846.52 tons per year, while the Bogor City compost house has only been operating for the past 2 years and can only process approximately 22 tons per year (Joseph, 2014). This is due to the constraints of human resources (HR) and technology so that food waste cannot be maximized. Therefore, currently, the Galuga landfill is also processing food waste into compost to lessen the quantity of garbage that ends up in landfills which can be seen in Figure 7.

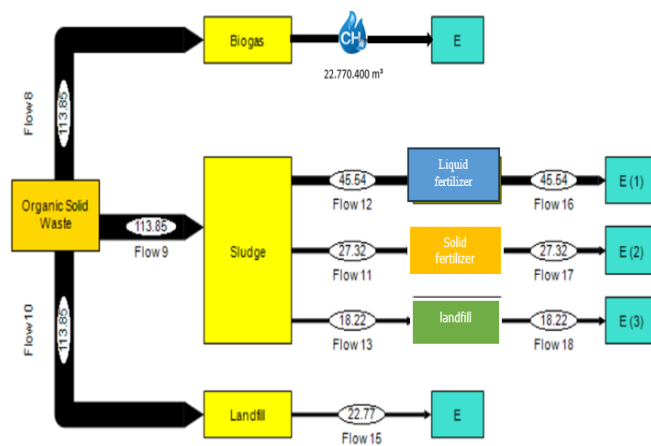

**Figure 7.** Existing Composting In Galuga Landfill

Next is the determination of scenario 2, namely anaerobic processing technology that produces biogas. Anaerobic processing has the ability to generate power and can extend the usable life of landfills by lowering the

quantity and volume of municipal garbage (Leme et al., 2024). According to study by Couth et al., (2011), solid waste has the potential to be mitigated through the use of renewable energy (biogas) because it is a substantial source of methane emissions. Methane produced from the solid waste processing process is a viable option for electricity generation (Jao et al., 2024). Organic waste processing that produces landfill gas is carried out through a five-step procedure (Gillett & Tauati, 2018): (1) aerobic hydrolysis and degradation that converts easily decomposed carbohydrates into simple sugars, CO<sub>2</sub> and H<sub>2</sub>O (aerobic stage); (2) Simple sugars undergo hydrolysis and fermentation to produce soluble volatile acids (acidogenic stage); (3) soluble acids undergo conversion to acetic acid, H<sub>2</sub>, and CO<sub>2</sub> (acetogenic stage); (4) bacteria that produce methane break down acetate to produce CH<sub>4</sub> and CO<sub>2</sub> (methanogenic stage); and (5), aerobic (oxidation with restoration of aerobic conditions).

Anaerobic digestion (or biomethanation) is a process biodegradable organic matter without oxygen, and it stabilizes waste and generates biogas. Anaerobic processing organic waste can be used to agricultural land as organic additions or as soil moisturizers (Pivato et al., 2016). Browne et al., (2014) said that because the raw materials include unwanted substances, European legislation forbids using solid results from anaerobic digestion as fertilizer. Based on the advantages discussed from several previous studies in the previous paragraph, then if all food waste originating from Bogor City can be processed using an anaerobic process that produces biogas as scenario 2 can be seen in Figure 8.



**Figure 8.** Flowchart Of Biogas Processing (Scenario 2)

Based on the calculation of scenario 2, namely processing using anaerobic technology that produces biogas, Eighty percent of the digester's output is sludge, and food waste may be converted into biogas, a renewable energy source, and the remaining 20% is the remaining shrinkage of the total food waste (Bhatt et al., 2020; Gao et al., 2020; Pilarska et al., 2023; Wang et al., 2023; Kanellos et al., 2023). The resulting sludge can be reprocessed into a material that has high economic value, namely fertilizer. This fertilizer is obtained from the composting process by adding organic additives to produce fertilizer that has a physical form and macro

compounds that comply with SNI 19-1730-2004 standards. Fertilizers resulting from the composting process will experience severe shrinkage, this occurs because there is evaporation of water and gas content resulting from organic compost material's breakdown process by microorganisms. While the composting process is underway, it will also produce non-product output its quantity is determined by how well the process works and the quality of the raw materials (Nawansih et al., 2022). The final waste residue from the anaerobic process is approximately 35% of the total weight of organic waste that ends up in the landfill, thus reducing the excess load on the landfill's capacity, thereby extending the life of the landfill. The findings indicated that the landfill will have a ten-year lifespan or it can be said that the life of the Galuga landfill will be another 38 years. On the other hand, in reality, management with biogas technology cannot yet be implemented either at the RT/RW or central levels, but currently the Galuga landfill has conducted a small-scale biogas technology trial to lessen the quantity of garbage that ends up in landfills, which can be seen in Figure 9.

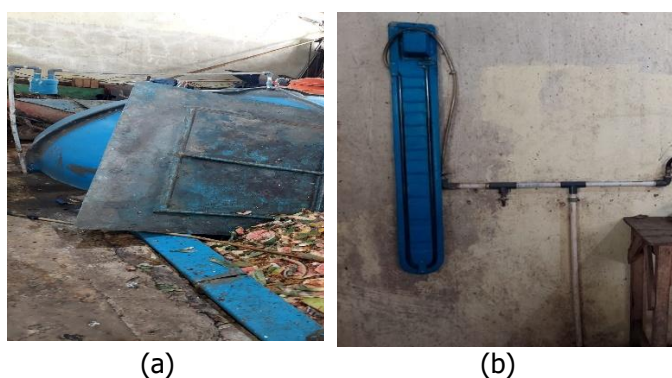
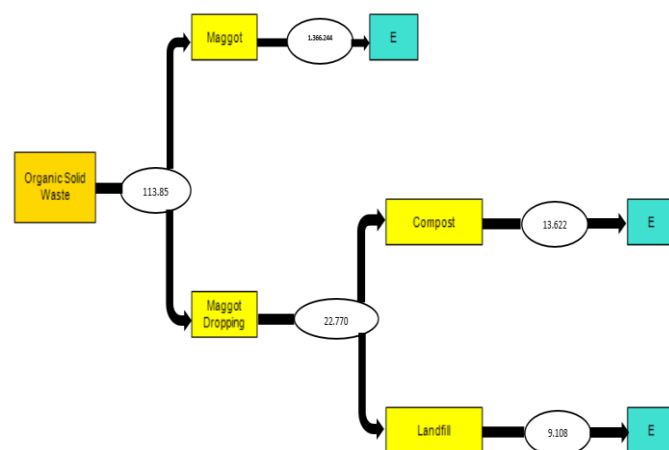

**Figure 9.** Biogas Processing In TPS 3R Cipaku Bogor City

Next is the determination of the 3rd scenario, namely CORS (Conversion of Organic Refuse by Saprophages) technology which produces a protein source. Insects can clean organic waste and turn it into higher-value products like high-protein feed or premium fertilizers, insects are a very attractive synthetic biology platform for enhancing sustainable biomanufacturing (Yanagihara et al., 2025). BSF is distributed globally except for Antarctica and BSF is not considered a pest species Black soldier fly (BSF) larvae, *Hermetia illucens* L. (Diptera: Stratiomyidae), digest organic waste as another CORS solution that combines income creation and nutrient recovery. Waste pre-processing (such as particle size reduction, dewatering, and inorganic waste disposal), BSFL organic waste processing, BSFL separation from process residues, and purification of larvae and residues into marketable products are all included in BSF organic waste processing facilities (Slimani et al., 2022). The system consists of a larval growth area and a BSF house where adults live and breed (da Silva & Hesselberg, 2020). To guarantee an adequate and ongoing supply of offspring for the digestion of organic waste, a rearing facility that preserves the health of adult BSF and larvae is necessary.

The daily consumption of organic materials by BSF larvae (BSFL) can reach 500 mg (Rahman & Alam, 2022).

The efficiency of organic waste processing using BSFL can reach 65.5-78.9%, in circumstances comparable to those of conventional composting techniques (Yang et al., 2025). BSFL can be a sustainable source of protein due to the high feed conversion efficiency of preconsumer food waste (Siva Raman et al., 2022). On average, prepupae have 33% fat and 44% crude protein (Ewald et al., 2020), this makes it a good substitute for fishmeal in animal feed. (Menino et al., 2021). One characteristic that sets BSFL apart is their ability to develop by consuming a lot of organic waste until they reach the prepupa stage (Salam et al., 2022). Insects are frequently utilized as wholesome animal and pet nutrition (Salam et al., 2022). Furthermore, it has been shown that insect meal is less costly than other protein feed ingredients like fishmeal. It is still more costly than soy protein, but it is seen to be a more environmentally friendly choice (de Souza Vilela et al., 2021). Based on the advantages discussed in several previous studies, all food waste from Bogor City can be processed using CORS processing with BSF as scenario 3 can be seen in Figure 10.



**Figure 10.** Flowchart Of Cors Processing (Scenario 3)

Based on Figure 9, the calculation of scenario 3, namely processing with CORS technology using BSF, then food waste can be reduced by 80% by maggots and the remaining 20% becomes kasgot which can then be reprocessed into compost (Pliantiangtam et al., 2021; Basri et al., 2022; Gebremikae et al., 2022; Ningsih et al., 2023; Piercy et al., 2023; Yunita, et al., 2024). During their roughly 21-day life cycle, maggots may devour up to 6 tons of organic trash, and at the end of their harvest, they weigh around 90 kg. In the CORS processing flow diagram, it will potentially produce final waste of 8% of the total weight of organic waste entering the landfill, it will reduce the excess load from the landfill's capacity so that it will extend the life of the landfill. The findings study indicated that the landfill's lifespan will be extended by 16 years or it can be said that the life of the Galuga landfill will be another 44 years. Therefore, currently, the Galuga landfill is also processing food waste in the landfill using CORS

technology to cut down on organic waste which Table 1 below provides a summary of the organic waste management performance based on the three scenarios.

**Table 1.**

Table Performance Of The Existing Galuga Landfill And Improvement Treatment Of Optional Scenarios

No	Criteria	Existing	Scenario1	Scenario2	Scenario3
1	Waste pile in Bogor City (ton/years)	284.631	284.631	284.631	284.631
2	Amount of food waste in Bogor City (ton/year)	113.852	113.852	113.852	113.852
3	Food waste that can be processed optimally with every scenario (ton/years)		68.311	72.864	104.704
4	The remaining waste that will go to the Galuga Landfill in Bogor City according to the scenario (ton/year)		45.541	40.986	9.108
5	Landfill life (years)	28	36	38	44

Based on the summary of Table 1, it can be seen that scenario 3 with CORS technology will produce less waste residue compared to scenarios 1 and 2, where the waste residue that goes to the landfill in scenario 1 is 40%; scenario 2 is 35%; and scenario 3 is 8%. In addition, the use of CORS technology can also extend the life of the landfill longer when compared to scenarios 1 and 2, where the age of the Galuga Landfill if implementing scenario 1 is 36 years; scenario 2 is 38 years; while scenario 3 is 44 years.

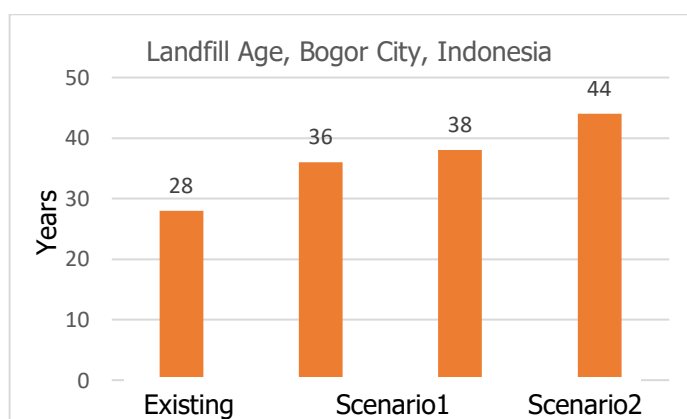

**Figure 11.** Landfill Age, Bogor City, Indonesia

## CONCLUSIONS

In the context of urbanization and the consequent escalation of organic solid waste generation, innovative waste management strategies are paramount. Among various strategies evaluated, Scenario 3 demonstrates remarkable potential due to its dual focus on economic benefit and environmental sustainability. This paper delves into the specifics of Scenario 3, emphasizing its ability to convert organic waste into economically valuable products while ultimately diminishing the volume of waste sent to landfills.

The core of Scenario 3 lies in the conversion of organic waste into high-value byproducts. The utilization of maggots, particularly larvae of the black soldier fly (*Hermetia illucens*), has garnered significant attention for its role in protein recycling. These maggots are rich in protein—comprising nearly 50% of their dry weight—which makes them an ideal source of animal feed, particularly for poultry, aquaculture, and livestock industries. This aspect not only addresses the urgent need for sustainable protein sources in animal husbandry but also directly correlates to reduced feed costs for farmers, promoting economic resilience in the agricultural sector.

Moreover, the byproduct of maggot cultivation—maggot droppings, or frass—holds substantial value as an organic fertilizer. The nutrient profile of frass includes essential macronutrients such as nitrogen, phosphorus, and potassium, alongside beneficial microbes which enhance soil health. Composting these droppings can yield a quality organic fertilizer, bolstering crop yields and promoting sustainable agricultural practices. The dual utility of maggots as a protein source and their frass as

fertilizer demonstrates a symbiotic relationship between ecological sustainability and economic advantage.

## SUGGESTION

The implementation of these three scenarios is still limited by constraints related to human resources and technology, which prevents the maximization of food waste reduction. Therefore, more actions are required to maximize human resources and evaluate the readiness and availability of readily adoptable technologies, especially at the home level.

Analytically, Scenario 3 posits a transformative shift in waste management paradigms. With projections indicating that only approximately 8% of the total weight of organic solid waste would reach landfills following the implementation of this strategy, significant reductions in waste volume are anticipated. Such a decrease in landfill dependency is noteworthy; it directly correlates to an extended operational capacity of landfill sites. Given the pressing issue of landfill overcapacity in many urban locales, enhancing the lifespan of existing facilities by an estimated 63% could remarkably alleviate some environmental pressures associated with landfill use.

This reduction in waste directed to landfills also holds substantial environmental implications. Decreased landfill loads can mitigate greenhouse gas emissions, such as methane—a potent contributor to climate change—which are commonly emitted during the decomposition of organic waste. Furthermore, the reduction of leachate, a toxic byproduct arising from landfill sites, may lead to improved groundwater quality in surrounding areas.

## REFERENCES

- Adelodun, B., Ajibade, F. O., Tihamiyu, A. G. O., Nwogwu, N. A., Ibrahim, R. G., Kumar, P., Kumar, V., Odey, G., Yadav, K. K., Khan, A. H., Cabral-Pinto, M. M. S., Kareem, K. Y., Bakare, H. O., Ajibade, T. F., Naveed, Q. N., Islam, S., Fadare, O. O., & Choi, K. S. (2021). Monitoring the presence and persistence of SARS-CoV-2 in water-food-environmental compartments: State of the knowledge and research needs. *Environmental Research*, 200, 111373. [\[Crossref\]](#) [\[Publisher\]](#)
- Agarwal, S., Han, Y., Qin, Y., & Zhu, H. (2023). Disguised pollution: Industrial activities in the dark. *Journal of Public Economics*, 223, 104904. [\[Crossref\]](#) [\[Publisher\]](#)
- Amicarelli, V., Lagioia, G., & Bux, C. (2021). Global warming potential of food waste through the life cycle assessment: An analytical review. *Environmental Impact Assessment Review*, 91. [\[Crossref\]](#) [\[Publisher\]](#)
- Annisa, B. (2019). Asesmen Aliran Kritis Sistem Pengelolaan Sampah Perkotaan di TPA Sampah. *SPECTA Journal of Technology*, 1(2), 41–53. [\[Crossref\]](#) [\[Publisher\]](#)
- Arun, C., & Sivashanmugam, P. (2015). Investigation of biocatalytic potential of garbage enzyme and its influence on stabilization of industrial waste activated sludge. *Process Safety and Environmental Protection*, 94(C), 471–478. [\[Crossref\]](#) [\[Publisher\]](#)
- Aschemann-Witzel, J., Otterbring, T., de Hooge, I. E., Normann, A., Rohm, H., Almlí, V. L., & Oostindjer, M. (2019). The who, where and why of choosing suboptimal foods: Consequences for tackling food waste in store. *Journal of Cleaner Production*, 236, 117596. [\[Crossref\]](#) [\[Publisher\]](#)
- Aydoğmuş, M., Gülay, G., & Ergun, K. (2022). Impact of ESG performance on firm value and profitability. *Borsa Istanbul Review*, 22, S119–S127. [\[Crossref\]](#) [\[Publisher\]](#)
- Bhattacharai, S., Regmi, B. R., Pant, B., Uprety, D. R., & Maraseni, T. (2021). Sustaining ecosystem based adaptation: The lessons from policy and practices in Nepal. *Land Use Policy*, 104, 105391. [\[Crossref\]](#) [\[Publisher\]](#)
- Bian, R., Xin, D., & Chai, X. (2018). A Simulation model for estimating methane oxidation and emission from landfill cover soils. *Waste Management*, 77, 426–434. [\[Crossref\]](#) [\[Publisher\]](#)
- Browne, J. D., Allen, E., & Murphy, J. D. (2014). Assessing the variability in biomethane production from the organic fraction of municipal solid waste in batch and continuous operation. *Applied Energy*, 128, 307–314. [\[Crossref\]](#) [\[Publisher\]](#)
- Burin, T., Grohar, M. C., Jakopic, J., Veberic, R., & Hudina, M. (2025). Fermented olives (*Olea europaea* L.): A detailed insight into morphological changes and phenolic profile from harvest to jar. *Food Chemistry: X*, 26, 102309. [\[Crossref\]](#) [\[Publisher\]](#)
- Camilleri, M. A. (2025). Sustainability accounting and disclosures of responsible restaurant practices in environmental, social and governance (ESG) reports. *International Journal of Hospitality Management*, 126, 104051. [\[Crossref\]](#) [\[Publisher\]](#)
- Couth, R., Trois, C., & Vaughan-Jones, S. (2011). Modelling of greenhouse gas emissions from municipal solid waste disposal in Africa. *International Journal of Greenhouse Gas Control*, 5(6), 1443–1453. [\[Crossref\]](#) [\[Publisher\]](#)
- Cudjoe, D., & Acquah, P. M. (2021). Environmental impact analysis of municipal solid waste incineration in African countries. *Chemosphere*, 265, 129186. [\[Crossref\]](#) [\[Publisher\]](#)
- da Silva, G. D. P., & Hesselberg, T. (2020). A Review of the Use of Black Soldier Fly Larvae, *Hermetia illucens* (Diptera: Stratiomyidae), to Compost Organic Waste in Tropical Regions. *Neotropical Entomology*, 49(2), 151–162. [\[Crossref\]](#) [\[Publisher\]](#)
- de Souza Vilela, J., Andronicos, N. M., Kolakshyapati, M., Hilliar, M., Sibanda, T. Z., Andrew, N. R., Swick, R. A., Wilkinson, S., & Ruhnke, I. (2021). Black soldier fly larvae in broiler diets improve broiler performance and modulate the immune system. *Animal Nutrition*, 7(3), 695–706. [\[Crossref\]](#) [\[Publisher\]](#)
- Dhir, A., Talwar, S., Kaur, P., & Malibari, A. (2020). Food waste in hospitality and food services: A systematic literature review and framework development approach. *Journal of Cleaner Production*, 270. [\[Crossref\]](#) [\[Publisher\]](#)

- Di Foggia, G., & Beccarello, M. (2021). Designing waste management systems to meet circular economy goals: The Italian case. *Sustainable Production and Consumption*, 26, 1074–1083. [[Crossref](#)] [[Publisher](#)]
- Ewald, N., Vidakovic, A., Langeland, M., Kiessling, A., Sampels, S., & Lalander, C. (2020). Fatty acid composition of black soldier fly larvae (*Hermetia illucens*) – Possibilities and limitations for modification through diet. *Waste Management*, 102, 40–47. [[Crossref](#)] [[Publisher](#)]
- Fan, X., Liu, Z., Norbeck, J. M., & Park, C. S. (2016). A simple kinetic analysis of syngas during steam hydrogasification of biomass using a novel inverted batch reactor with instant high pressure feeding. *Bioresource Technology*, 200, 731–737. [[Crossref](#)] [[Publisher](#)]
- Fuss, M., Vergara-Araya, M., Barros, R. T. V., & Pogonietz, W. R. (2020). Implementing mechanical biological treatment in an emerging waste management system predominated by waste pickers: A Brazilian case study. *Resources, Conservation and Recycling*, 162, 105031. [[Crossref](#)] [[Publisher](#)]
- Galiwango, E., & A.Gabbar, H. (2022). Synergistic interactions, kinetic and thermodynamic analysis of co-pyrolysis of municipal paper and polypropylene waste. *Waste Management*, 146, 86–93. [[Crossref](#)] [[Publisher](#)]
- Gillett, R., & Tauati, M. (2018). Food and Agriculture Organization of the United Nations, 2018. Fisheries of the Pacific islands: regional and national information. *FAO Fisheries and Aquaculture Technical Paper*, 279. [[Publisher](#)]
- Gustafsson, H., Skoog, T., Podlog, L., Lundqvist, C., & Wagnsson, S. (2013). Hope and athlete burnout: Stress and affect as mediators. *Psychology of Sport and Exercise*, 14(5), 640–649. [[Crossref](#)] [[Publisher](#)]
- Habibur Rahman, M., Fashiar Rahman, M., & Tseng, T. L. (2023). Estimation of fuel consumption and selection of the most carbon-efficient route for cold-chain logistics. *International Journal of Systems Science: Operations and Logistics*, 10(1). [[Crossref](#)] [[Publisher](#)]
- Jäger-Roschko, M., & Petersen, M. (2022). Advancing the circular economy through information sharing: A systematic literature review. *Journal of Cleaner Production*, 369, 133210. [[Crossref](#)] [[Publisher](#)]
- Jao, J., Toyokan, M., Vallar, E., Silva, L., & Galvez, M. C. (2024). Assessment of Municipal Solid Waste Management Scenarios in Metro Manila Using the Long-Range Energy Alternatives Planning-Integrated Benefit Calculator (LEAP-IBC) System. *Sustainability (Switzerland)*, 16(14), 6246. [[Crossref](#)] [[Publisher](#)]
- Jerie, S., Shabani, T., & Shabani, T. (2024). Life cycle assessment of household food waste in Zimbabwe: a systematic review. *Discover Food*, 4(1). [[Crossref](#)] [[Publisher](#)]
- Jin, H. Y., Yang, L., Ren, Y. X., Tang, C. C., Zhou, A. J., Liu, W., Li, Z., Wang, A., & He, Z. W. (2023). Insights into the roles and mechanisms of a green-prepared magnetic biochar in anaerobic digestion of waste activated sludge. *Science of The Total Environment*, 896, 165170. [[Crossref](#)] [[Publisher](#)]
- Jindal, M. K., & Sar, S. K. (2023). Medical waste management during COVID-19 situation in India: Perspective towards safe environment. *Waste Management Bulletin*, 1(1), 1–3. [[Crossref](#)] [[Publisher](#)]
- Joseph, K. (2014). Municipal Solid Waste Management in India. In *Environmental Science and Engineering* (pp. 113–138). Springer Singapore. [[Crossref](#)] [[Publisher](#)]
- Kala, K., Bolia, N. B., & Sushil. (2022). Analysis of informal waste management using system dynamic modelling. *Heliyon*, 8(8), e09993. [[Crossref](#)] [[Publisher](#)]
- Karakadzai, T., Matamanda, A. R., & Chirisa, I. (2021). Rainwater Harvesting for Water Security in Informal Settlements: Techniques, Practices, and Options. *The Palgrave Encyclopedia of Urban and Regional Futures*, 1–11. [[Crossref](#)] [[Publisher](#)]
- Kashyap, R., Kuttippurath, J., & Kumar, P. (2023). Browning of vegetation in efficient carbon sink regions of India during the past two decades is driven by climate change and anthropogenic intrusions. *Journal of Environmental Management*, 336, 117655. [[Crossref](#)] [[Publisher](#)]
- Koda, E., Winkler, J., Wowkonowicz, P., Černý, M., Kiersnowska, A., Pasternak, G., & Vaverková, M. D. (2022). Vegetation changes as indicators of landfill leachate seepage locations: Case study. *Ecological Engineering*, 174, 106448. [[Crossref](#)] [[Publisher](#)]
- Kundariya, N., Mohanty, S. S., Varjani, S., Hao Ngo, H., W. C. Wong, J., Taherzadeh, M. J., Chang, J. S., Yong Ng, H., Kim, S. H., & Bui, X. T. (2021). A review on integrated approaches for municipal solid waste for environmental and economical relevance: Monitoring tools, technologies, and strategic innovations. *Bioresource Technology*, 342, 125982. [[Crossref](#)] [[Publisher](#)]
- Le Pera, A., Sellaro, M., & Bencivenni, E. (2022). Composting food waste or digestate? Characteristics, statistical and life cycle assessment study based on an Italian composting plant. *Journal of Cleaner Production*, 350, 131552. [[Crossref](#)] [[Publisher](#)]
- Leme, M. A. de G., Torres-Mayanga, P. C., Lachos-Perez, D., Forster-Carneiro, T., & Miguel, M. G. (2024). Biogas production from the landfilled easily degradable fraction of municipal solid waste: mining strategy for energy recovery. *Biomass Conversion and Biorefinery*, 14(10), 10947–10958. [[Crossref](#)] [[Publisher](#)]
- Leon, A. (2024). A synthesis of the evidence regarding the efficacy of alternative field management practices in rice cultivation using life cycle assessment. *Science of The Total Environment*, 926, 171693. [[Crossref](#)] [[Publisher](#)]
- Lesmana, R. Y., & Tawaqal, G. I. (2021). Rencana Kebutuhan Luas Lahan Tempat Pemrosesan Akhir Sampah (TPA) Tipe Sanitary Landfill untuk Sampah dari Kecamatan Pahandut. *Media Ilmiah Teknik*

- Lingkungan*, 6(1), 11–15. [[Crossref](#)] [[Publisher](#)]
- López-González, J. A., Vargas-García, M. del C., López, M. J., Suárez-Estrella, F., Jurado, M., & Moreno, J. (2014). Enzymatic characterization of microbial isolates from lignocellulose waste composting: Chronological evolution. *Journal of Environmental Management*, 145, 137–146. [[Crossref](#)] [[Publisher](#)]
- Makan, A., Fadili, A., & Oubenali, M. (2020). Interaction of physicochemical parameters during pressurized in-vessel composting of food waste. *Bioresource Technology Reports*, 10, 100350. [[Crossref](#)] [[Publisher](#)]
- Maleknia, R. (2025). Roots of urban forest conservation behaviors: Discovering determinants of citizens' attitudes. *Environmental and Sustainability Indicators*, 26, 100671. [[Crossref](#)] [[Publisher](#)]
- Menino, R., Felizes, F., Castelo-Branco, M. A., Fareleira, P., Moreira, O., Nunes, R., & Murta, D. (2021). Agricultural value of Black Soldier Fly larvae frass as organic fertilizer on ryegrass. *Heliyon*, 7(1), e05855. [[Crossref](#)] [[Publisher](#)]
- Nawansih, O., Abdillah, H. B., Herdiana, N., & Winanti, D. D. T. (2022). Peningkatan umur simpan kolang-kaling dengan larutan ekstrak kayu manis (*Cinnamomum burmannii*) dan ekstrak cengkeh (*Syzygium aromaticum*) sebagai bahan pengawet alami. *Agrointek: Jurnal Teknologi Industri Pertanian*, 16(2), 234–241. [[Crossref](#)] [[Publisher](#)]
- Nurzaki, A. A. (2021). *Perencanaan Dan Desain Pengelolaan Sampah Sanitary Landfill Di Tpa Galuga Bogor Jawa Barat*. [[Publisher](#)]
- O'Connor, J., Mickan, B. S., Gurung, S. K., Siddique, K. H. M., Leopold, M., & Bolan, N. S. (2023). Enhancing nutrient recovery from food waste anaerobic digestate. *Bioresource Technology*, 390, 129869. [[Crossref](#)] [[Publisher](#)]
- Ouzeau, G., Soubeyroux, J. M., Schneider, M., Vautard, R., & Planton, S. (2016). Heat waves analysis over France in present and future climate: Application of a new method on the EURO-CORDEX ensemble. *Climate Services*, 4, 1–12. [[Crossref](#)] [[Publisher](#)]
- Pivato, A., Vanin, S., Raga, R., Lavagnolo, M. C., Barausse, A., Rieple, A., Laurent, A., & Cossu, R. (2016). Use of digestate from a decentralized on-farm biogas plant as fertilizer in soils: An ecotoxicological study for future indicators in risk and life cycle assessment. *Waste Management*, 49, 378–389. [[Crossref](#)] [[Publisher](#)]
- Rahman, M. M., & Alam, K. (2022). The roles of globalization, renewable energy and technological innovation in improving air quality: Evidence from the world's 60 most open countries. *Energy Reports*, 8, 9889–9898. [[Crossref](#)] [[Publisher](#)]
- Salam, M., Shahzadi, A., Zheng, H., Alam, F., Nabi, G., Dezhi, S., Ullah, W., Ammara, S., Ali, N., & Bilal, M. (2022). Effect of different environmental conditions on the growth and development of Black Soldier Fly Larvae and its utilization in solid waste management and pollution mitigation. *Environmental Technology & Innovation*, 28, 102649. [[Crossref](#)] [[Publisher](#)]
- SHABANI, T., & JERIE, S. (2022). *A Review of the Effectiveness of the Integrated Solid Waste Management System in Institutional Solid Waste Management in Zimbabwe*. [[Crossref](#)] [[Publisher](#)]
- Shen, Z., Fang, Y., & Yuan, B. (2025). Chitosan-based films with excellent flame retardancy and highly sensitive fire response for application in self-powered dual fire-alarm systems. *International Journal of Biological Macromolecules*, 299, 140131. [[Crossref](#)] [[Publisher](#)]
- Siles-Castellano, A. B., López, M. J., López-González, J. A., Suárez-Estrella, F., Jurado, M. M., Estrella-González, M. J., & Moreno, J. (2020). Comparative analysis of phytotoxicity and compost quality in industrial composting facilities processing different organic wastes. *Journal of Cleaner Production*, 252, 119820. [[Crossref](#)] [[Publisher](#)]
- Simeone, M., & Scarpato, D. (2020). Sustainable consumption: How does social media affect food choices? *Journal of Cleaner Production*, 277, 124036. [[Crossref](#)] [[Publisher](#)]
- Siva Raman, S., Stringer, L. C., Bruce, N. C., & Chong, C. S. (2022). Opportunities, challenges and solutions for black soldier fly larvae-based animal feed production. *Journal of Cleaner Production*, 373, 133802. [[Crossref](#)] [[Publisher](#)]
- Slimani, N., Wood, P. J., Guilbert, E., Boumaiza, M., & Sánchez-Fernández, D. (2022). Using biodiversity indicators to identify priority areas for freshwater conservation in the African "Mediterranean Basin" biodiversity hotspot. *Biological Conservation*, 276, 109783. [[Crossref](#)] [[Publisher](#)]
- Sparkes, E., Totin, E., Werners, S. E., Wise, R. M., Butler, J. R. A., & Vincent, K. (2023). Adaptation pathways to inform policy and practice in the context of development. *Environmental Science & Policy*, 140, 279–285. [[Crossref](#)] [[Publisher](#)]
- Spokas, K., Graff, C., Morcet, M., & Aran, C. (2003). Implications of the spatial variability of landfill emission rates on geospatial analyses. *Waste Management*, 23(7), 599–607. [[Crossref](#)] [[Publisher](#)]
- Sun, Y. (2024). Waste oxy-fuel combustion integrated with supercritical CO<sub>2</sub> cycle and high-temperature electrolysis technologies for e-methanol production: A feasibility analysis. *Process Safety and Environmental Protection*, 185, 225–238. [[Crossref](#)] [[Publisher](#)]
- Thushari, G. G. N., & Senevirathna, J. D. M. (2020). Plastic pollution in the marine environment. *Heliyon*, 6(8), e04709. [[Crossref](#)] [[Publisher](#)]
- Tomba, C., Luchnikov, V., Barberi, L., Blanch-Mercader, C., & Roux, A. (2022). Epithelial cells adapt to curvature induction via transient active osmotic swelling. *Developmental Cell*, 57(10), 1257-1270.e5. [[Crossref](#)] [[Publisher](#)]
- V. L. Leonard, S., Liddle, C. R., Atherall, C. A., Chapman, E., Watkins, M., D. J. Calaminus, S., & Rotchell, J. M. (2024). Microplastics in human blood: Polymer types, concentrations and characterisation using µFTIR. *Environment International*, 188, 108751. [[Crossref](#)]

- [[Publisher](#)]
- Varjani, S. J., & Upasani, V. N. (2017). A new look on factors affecting microbial degradation of petroleum hydrocarbon pollutants. *International Biodeterioration & Biodegradation*, 120, 71–83. [[Crossref](#)] [[Publisher](#)]
- Varjani, S., Shahbeig, H., Popat, K., Patel, Z., Vyas, S., Shah, A. V., Barceló, D., Hao Ngo, H., Sonne, C., Shiung Lam, S., Aghbashlo, M., & Tabatabaei, M. (2022). Sustainable management of municipal solid waste through waste-to-energy technologies. *Bioresource Technology*, 355, 127247. [[Crossref](#)] [[Publisher](#)]
- Wang, Q., & Su, M. (2020). A preliminary assessment of the impact of COVID-19 on environment – A case study of China. *Science of The Total Environment*, 728, 138915. [[Crossref](#)] [[Publisher](#)]
- Xie, X., Hoang, T. T., & Zhu, Q. (2022). Green process innovation and financial performance: The role of green social capital and customers' tacit green needs. *Journal of Innovation & Knowledge*, 7(1), 100165. [[Crossref](#)] [[Publisher](#)]
- Yaashikaa, P. R., Kumar, P. S., Saravanan, A., Varjani, S., & Ramamurthy, R. (2020). Bioconversion of municipal solid waste into bio-based products: A review on valorisation and sustainable approach for circular bioeconomy. *Science of the Total Environment*, 748, 141312. [[Crossref](#)] [[Publisher](#)]
- Yanagihara, T. K., Tepper, J. E., Moon, A. M., Barry, A., Molla, M., Seong, J., Torres, F., Apisarnthanarax, S., Buckstein, M., Cardenes, H., Chang, D. T., Feng, M., Guha, C., Hallemeier, C. L., Hawkins, M. A., Hoyer, M., Iwata, H., Jabbour, S. K., Kachnic, L., ... Dawson, L. A. (2025). Erratum to: Defining Minimum Treatment Parameters of Ablative Radiation Therapy in Patients With Hepatocellular Carcinoma: An Expert Consensus. Yanagihara TK, Tepper JE, Moon AM, et al. *Pract Radiat Oncol*. 2024 Mar-Apr;14(2):134-145. *Practical Radiation Oncology*, 15(2), 214–215. [[Crossref](#)] [[Publisher](#)]
- Yang, Y., Qi, C., Gu, Y., & Fang, G. (2025). Correction to: Use Efficiency, Reduction Potential, and Effects of Fertilizers on Carbon Emissions in China's Major Citrus Regions (Agriculture, (2024), 14, 11, (1971), 10.3390/agriculture14111971). *Agriculture (Switzerland)*, 15(1), 15010072. [[Crossref](#)] [[Publisher](#)]
- Yasmeen, H., & Longsheng, C. (2025). Advancing circular economy in the equipment manufacturing sector: The role of environmental management systems, innovation and policy support. *Journal of Environmental Management*, 380, 124967. [[Crossref](#)] [[Publisher](#)]
- Yiwei, F., Jiayelu, W., Mingming, W., Shenghai, Y., Rongrong, Z., Jing, Y., Guofu, Z., Faming, Y., Yanting, L., & Xiaoming, Z. (2024). Progress on Molecular Mechanism of Heat Tolerance in Rice. *Rice Science*, 31(6), 673–687. [[Crossref](#)] [[Publisher](#)]
- Zhang, L., & Sun, X. (2023). Food waste and montmorillonite contribute to the enhancement of green waste composting. *Process Safety and Environmental Protection*, 170, 983–998. [[Crossref](#)] [[Publisher](#)]